

Guide for the assembly of tensegrity robots

The Faboratory – Yale University

By Cimatti Luca, luca.cimatti@yale.edu

For more information contact:

Will Johnson, PhD candidate at the Faboratory, Yale University:

will.johnson@yale.edu

Prof. Rebecca Kramer-Bottiglio, director of the Faboratory, Yale University:

rebecca.kramer@yale.edu

Contents

Disclaimer.....	1
Sensors.....	2
Short sensors	2
Long sensors	4
Sensor's jumpers.....	6
End caps cover.....	7
3D printed parts and further assembling	8
Post-print procedures.....	9
Motor enclosure – Part A	9
Electronics enclosure – Part A.....	13
End caps.....	14
Electronics.....	16
Motherboard.....	16
Other components	21
Final assembly of the rod	22
Final assembly of the robot – 3 bars	24
EXTRAS	27
Connector for recharge station	27
How to charge the robot	28
How to switch on/off the rods	29
How to upload the code in the rod	29

Disclaimer

This is a step-by-step guide on the assembling of the tensegrity robot in development at The Faboratory, Yale University, and it is dated 12/05/2024. If the version of the robot changes this guide may be no longer valid. For the details on the parts used in the robot, see the BOM of the robot.

In this guide there will be some indications as follows:



= **Tips**: this sign will be used to indicate some useful strategies that simplify the task



= **Warnings**: this sign will be used to indicate something that must be watched out



= **Dangers**: this sign will be used to indicate something that may be dangerous for the person or for the desired result.

Also, if some words are colored with the colors above, the meaning is the same.

This will be the result!

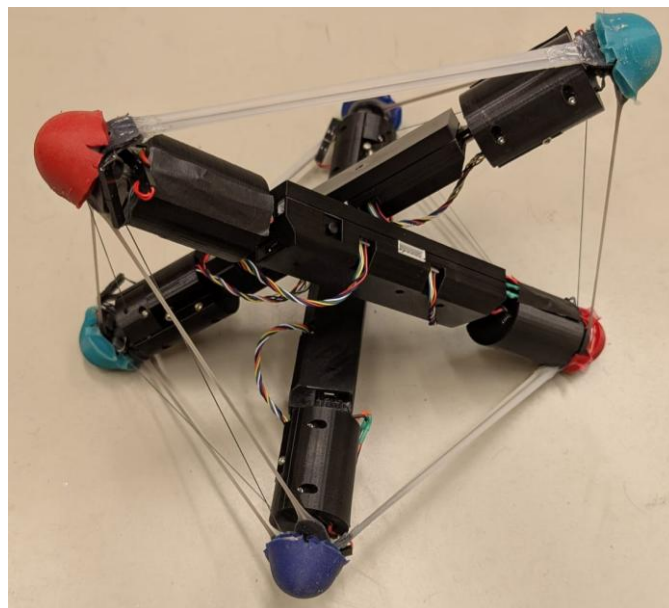

Sensors

In this section will be described how to build the stretchable sensors for the robot.

Short sensors



Things you'll need – per batch (17 sensors)

- **EcoFlex 30 – Part A:** ~100 g (total)
- **EcoFlex 30 – Part B:** ~100 g (total)
- **oGaln paste:** as much as needed
- **Fabric ends:** 4
- **Fabric strip:** 1
- **Paper sheet:** 2
- **Laser cutter:** 1
- **Draw bar:** 1
- **Plastic cup:** 1
- **Popsicle sticks:** as much as needed
- **Toothpicks:** as much as needed
- **Gloves:** as much as needed
- **0.004” PET film:** a rectangle of 30x50 cm
- **Wire stripper:** 1
- **0.6 mm wire (29 AWG ultra-flexible silicon wire):** 34x45 mm
- **Tape:** as much as needed
- **Marker:** 1
- **Scale:** 1
- **Paper towels:** as much as needed
- **Knife:** 1
- **Isopropanol:** as much as needed
- **Male crimp pin:** 34
- **Crimp housing:** 17
- **Crimper:** 1
- **Soldering iron:** 1
- **Solder:** as much as needed
- **Simple green:** as much as needed
- **Time:** >8 hours

Prior preparations

1. Cut the paper sheet with the laser cutter to form two identical paper masks with seventeen traces and four indentations along the short sides
2. Cut the thirty-four 29 AWG ultra-flexible silicon wire, strip about 3 mm off one of the ends of the wire and create a little hook



Keep them as straight as possible, an effective way to do it is, after the hook is created, to twist the wire and try to make them straighter.

3. Cut the 0.004” PET film as indicated before and place it on a table, use the tape to block it in position
4. Place one of the paper masks at the center of the plastic film and mark the indentations and the corners with the marker on the plastic film
5. Prepare some popsicle sticks and toothpicks and put them on the plastic sheet

Preparation

1. Mix 60 g of Eco-Flex 00-30
2. Take the 2 fabric ends and, using a popsicle stick, wet them with the Eco-Flex 00-30. **They must be wet but scoop away all the excess**
3. Place the two fabric ends previously wet between the corners and the indentations
4. Place the draw bar at the left of plastic sheet, the fabric ends must be completely inside the draw bar
5. Pour the Eco-Flex in front of the draw bar and move the draw bar forward, in a **straight line**, to form a homogeneous layer of mixture

 Use a popsicle stick to help pour the mixture, try to scoop everything out

6. Let the mixture cure for **at least 2 hours**
7. Take one of the paper masks and place, carefully, on the precedent made signs and in correspondence of the fabric ends
8. Take the oGaln paste and, with a popsicle stick, take some of it and spread it on the silicon over the mask. The layer must not be too thick, so scrape away all the excess but be sure that the whole trace is fully coated in oGaln
9. **Carefully**, remove the paper mask

 Use a toothpick to remove the mask

10. Adjust the trace of oGaln, if some of the paste is outside of the original trace, clean it with a toothpick and some simple green
11. Take the wire previously cut and place them with the little hook on the oGaln pad

 Place the wire in a way that it does not pass on the hole of the fabric string. It must be also straighter as possible

12. Take a toothpick and take a drop of the oGaln paste and put it on the hook. It must not be too much but it must cover and, in some ways, fix in position the wire
13. Repeat the step 1
14. Take the fabric strip, wet it with the mixture and place it on the fixed hooks

 Be extremely careful doing point 14 because the wires can move and if they exit from their place that sensor is ruined

15. Repeat steps from 4 to 6
16. Repeat step 1
17. Repeat steps from 4 to 6
18. Repeat steps 1 and 2
19. Repeat steps from 7 to 12
20. Repeat steps 1 and 14
21. **Keeping the PET**, move to the laser cutter and cut the sensors out

22. Using a knife, remove the excess of the material from the sensors
23. **Carefully**, free the wires from the silicon
24. Using some ethanol and paper towels, clean the sensors from the subproducts of the cutting
25. Cut the wires to be the same length
26. Using the wire stripper, strip the final part of the wires, **like 3-4 mm**
27. Apply one crimp at the end of each wire
28. Using the crimper, close the connector on the end of the wires, **there are two of them**
29. Using the Soldering iron, apply some Solder on the wires in the crimp to secure the position
30. Twist the wires, **in this way they will stay in position**
31. Apply the crimp housing inserting the connector in it until you hear a slight “click”

Long sensors



Things you'll need – per batch (14 sensors)

- **DragonSkin 30 – Part A:** ~150 g (total)
- **DragonSkin 30 – Part B:** ~150 g (total)
- **oGaln alloy:** as much as needed
- **Fabric ends:** 4
- **Fabric strip:** 1
- **Paper sheet:** 2
- **Laser cutter:** 1
- **Draw bar:** 1
- **Plastic cup:** 2
- **Popsicle sticks:** as much as needed
- **Toothpicks:** as much as needed
- **Gloves:** as much as needed
- **0.004” PET film:** a rectangle of 30x50 cm
- **Wire stripper:** 1
- **0.6 mm wire (29 AWG ultra-flexible silicon wire):** 34x45 mm
- **Tape:** as much as needed
- **Marker:** 1
- **Scale:** 1
- **Paper towels:** as much as needed
- **Knifer:** 1
- **Ethanol:** as much as needed
- **Male crimp pin:** 28
- **Crimp housing:** 14
- **Crimper:** 1
- **Soldering iron:** 1
- **Solder:** as much as needed
- **Sil-poxy:** as much as needed
- **Oven:** 1
- **Random piece of rigid plastic:** 2
- **Time:** ~4 days

Prior preparations

1. Using the laser cutter, cut the paper sheet to form a paper mask with fourteen traces and four indentations along the short sides
2. Cut the 28 wire pieces, strip ~3 mm off one of the ends of the wire and create a little hook



Keep them as straight as possible, an effective way to do it is, after the hook is created, to twist the wire and try to make them straighter.

3. Cut the plastic sheet as indicated before and place it on a table, use the tape to block it in position
4. Place one of the paper masks at the center of the plastic sheet and mark the indentations and the corners with the marker on the plastic sheet
5. Prepare some popsicle sticks and toothpicks and put them on the plastic sheet

Preparation

1. Mix 60 g of DragonSkin 20
2. Helping yourself with a popsicle stick spread some of the mixture on two of the fabric ends with holes
3. Place the fabric ends on the plastic film at the corners previously marked
4. Pour the DragonSkin on the PET and, using the draw bar, spread it on the film keeping it outside of the sign
5. Leave it set overnight
6. Place the paper mask used to make the sign on the film and align it with the signs and with the fabric ends
7. Using a popsicle stick, spread the oGaln paste on the holes of the mask, scrape away the excess. To do this, **WEAR GLOVES AND LAB COAT**
8. **Carefully**, remove the paper mask
9. Take the previously prepared wires and put the hook on the oGaln pad, as straight as possible. Be sure that the wires are not passing on the holes of the fabric
10. Cover the hook with a drop of oGaln
11. Repeat the points from 1 to 9 but instead of making 60 grams, make ~100 g, **you will need two caps**
12. Spread some of the mixture on the thin fabric string
13. Place it on the largest part of the oGaln trace and push gently between the traces to be sure that the fabric is in contact with set DragonSkin
14. Place two rulers, one on top, over the fabric string with holes, and one on the wires
15. Take the draw bar and pour the mixture in front of it, **be sure to cover homogeneously everything**
16. Leave it set overnight
17. Repeat points from 6 to 10
18. Mix 100 g of DragonSkin 20, **you will need two caps**
19. Take the last two fabric ends and spread some of the mixture on them, scrape out the excess
20. Place the two fabric strip over the other two positioned in point 3
21. Repeat the point from 13 to 16
22. Keeping the PET, move to the laser cutter and cut the sensors out
23. Using the exacto knife, cut the sensors from the plastic film and from the excess of material



When cleaning the wires of excess plastic, DO NOT pull the wires, there is the risk of pulling them off the sensors. If this happens, the sensor is useless

24. Using some alcohol and some paper towels, clean the sensors from the remaining debris and dirt, resulting after the laser cut
25. **WAERING GLOVES**, take the Sil-poxy tube out of the fridge, a popsicle stick and two pieces of rigid plastic
26. Place the sensors on the rigid plastic pieces

27. Using a popsicle stick take some of the Sil-poxy from the tube and apply it at the junction between the fabric and the silicon part of the sensors
28. Put the Sil-poxy back in the fridge and throw away the popsicle stick
29. Put the sensors in the oven at a temperature between 40 and 60 °C for 15-20 minutes
30. Take them off the oven and, **WITH GLOVES**, touch the resin to test if it is fixed, if it is sticky put the sensors back in the oven for 5 more minutes
31. Turn the sensors and repeat the points from 25 to 30
32. With the wire stripper, strip the end of the wires, like 4-5 mm
33. Insert each wire's end in a crimp and, using the crimper, seal it
34. Using the soldering iron, apply some Solder on the wires in the crimp to secure their position.
Do not apply too much solder or it will be difficult to proceed with the following steps
35. Twist the wires a couple of times and insert them in the crimp housing, you can use a plier to pull the tip of the crimp through the crimp housing. Keep pulling the wire until you don't hear a slight "click"



Sometimes the click does not happen but the wire is fixed. If you think that the crimp is in position but you didn't hear the click, try to push it back, if it stays in position, it is fixed

Sensor's jumpers

Things you'll need – per part

- **0.6 mm wire (29 AWG ultra-flexible silicon wire) – red:** 1x120mm
- **0.6 mm wire (29 AWG ultra-flexible silicon wire) – black:** 1x120mm
- **Wire cutter:** 1
- **Wire stripper:** 1
- **Crimper:** 1
- **Famel crimp pin:** 4
- **Crimp housing:** 2
- **Soldering iron:** 1
- **Solder:** as much as needed
- **Tweezer:** 1
- **Time:** 10 minutes

Preparation

1. Cut the four pieces of wire, two red and two black, as indicated above
2. Strip both ends of the wires
3. Insert the end on a crimp and seal it with the crimper
4. Using the soldering iron, apply some Solder to fix the position of the wire
5. Insert the crimp in the crimp housing and push it in with the tweezers
6. Repeat the points from 3 to 5 for the other end of the wires

End caps cover

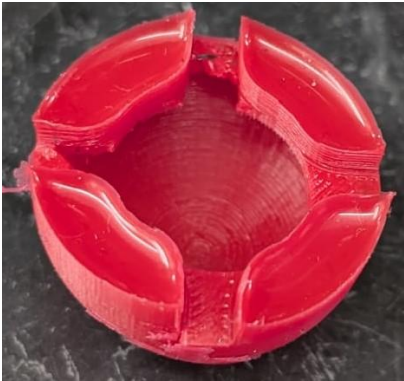

Things you'll need – per part

- **Inner mold:** 1
- **External mold:** 1
- **DragonSkin20 – part A:** ~ 10 g
- **DragonSkin20 – part B:** ~ 10 g
- **Ease to remove spray:** as much as needed
- **Fume hood:** 1 or a well-ventilated area
- **Dye:** as much as needed
- **Toothpick:** 1
- **Paper towel:** as much as needed
- **Knife:** 1
- **Clamp:** 1
- **Portable clamp:** 1
- **Time:** 1 day

The internal and external mold are two 3D printed components, presented in the pictures below. As you can see from the pictures, the inner part has some extended extremities that fit in the outer mold. After pouring DragonSkin 20 into the molds, pay attention to the right position of these extremities.



Prior preparations





1. Spray the ease to remove spray on the two parts of the mold in a well-ventilated area, ideally under a fume hood
2. Prepare a paper towel for the molds and for the cup, in this way the silicon will not spread on the table

Preparation

1. Mix 20 g of DragonSkin 20 and add the dye
2. Take the external mold and pour the resin inside, **do not pour too much**
3. Take the inner part and align it with the external mold
4. Leave them rest overnight
5. Put the external mold in the clamp and tight it as much as possible
6. With the portable clamp, remove the inner mold and the set cover from the external mold
7. Use the knife to help yourself to remove the end cap cover from the inner mold, try not to create cracks in it. Use the knife also to remove the parts of resin that are stuck in the mold

3D printed parts and further assembling

For the components present in the table below, use a Fused Filament Fabrication printer (FFF printer) or equivalent.

Parts		Settings			Time needed	Further cures	Notes
Name	Picture	Infill	Supports	N° / print			
Winch		100%	None	1	7 min	<ul style="list-style-type: none"> - Check for deformations - Tap the lateral hole (4-40 tap) - Insert the 4-40 set screw 	
Motor Enclosure - Part A		15%	None	1	3 h	Sometimes there is some material in the channel that will host the battery cable. Remove the excess material.	Check the following pages for more details
Motor Enclosure - Part B		15%	Support on build plate only	In batches	30 min	<ul style="list-style-type: none"> - Check for deformations - Remove supports - Insert the cable guide 	
Electronic enclosure - Part A		15%	Support on build plate only	1	2 h	<ul style="list-style-type: none"> - Check for deformations - Remove all the support, check all the holes 	Check the following pages for more details
Electronic enclosure - Part B		15%	Support on build plate only	1	2 h	<ul style="list-style-type: none"> - Check for deformations - Remove all the support 	

Post-print procedures

Motor enclosure – Part A

Things you'll need – per part

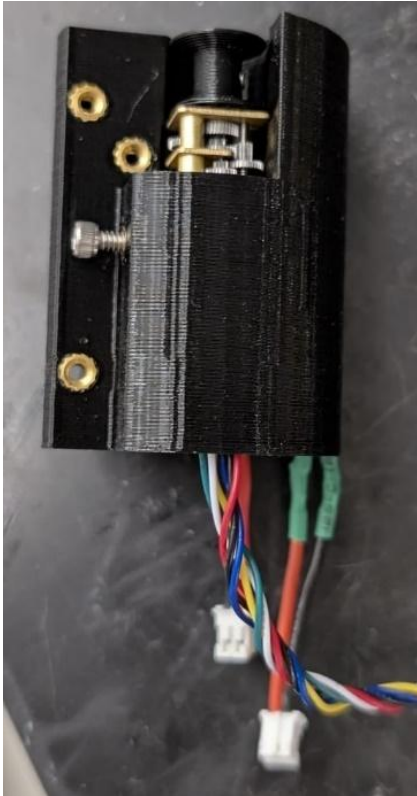

- **Soldering iron:** 1
- **Heat gun:** 1
- **Solder:** as much as needed
- **4-40 Heat-Set Threaded Inserts:** 4
- **4-40 Socket Head Cap Screws:** 4
- **Micro Metal Gearmotor HPCB 6V w/ Encoder:** 1
- **Motor wire (10cm JST-SH 6pos jumper cable):** 1
- **LiPo Battery 220 mAh:** 2
- **Male and female wires:** 1
- **Heat shrink:** as much as needed
- **Assembled Winch:** 1
- **Wire stripper:** 1
- **Scissor:** 1
- **Clamp:** 1
- **Sensor's jumpers:** 2 (one black and one red)
- **Black tape:** as much as needed
- **Fishing Line (500 YD/100 LB):** 450 mm
- **Motor Enclosure – part B:** 1
- **Time:** ~ 30 minutes

Please note the structure of the end mount – part A in the picture below:



Further in the guide there will be some references to “motor’s sit” and “batteries’ sit” and are the ones presented in this picture.

Further assembly

1. Take the motor and the preassembled winch, remove the setting screw and insert the shaft of the motor in the main hole of the winch



It is very hard, especially in the final part, **keep pushing**. At a certain point, the covering plastic of the motor will bend, **keep pushing**. Finally, the shaft will pass through the hole and it will reach the other side. Alline the planar part of the shaft with the hole in the side of the winch using the plies and insert back in the setting screw

2. Take the fishing line and make a double knot on the small hole of the winch, try to keep the knot on the inside of the winch
3. Wrap about half of the fishing line on the winch and try to maintain the knot and the excess of the fishing line under the wrap, the result of these first three steps is shown in the picture below:



4. Take the assembled motor and the motor wire and connect them, like in the picture below:



5. Take the male and female wires cut about 40 mm of the wire off the male one and about 50 mm off the female one
6. Strip the end of the wires of about 5 mm each
7. Solder the ends of the just striped ends of the wires



DO NOT TOUCH the metal part of the pipe but only the plastic part. Also **DO NOT TOUCH** the solder at its end and **DO NOT KEEP** your fingers too close to the final part.

8. Cut about 15-20 mm of heat retracting cover material, the green one
9. Insert the just cut green heat retracting cover on one of the wires of the male wire



Insert only one cover at a time, not both, there is the risk that the material will shrink in the wrong position.

10. Using the Soldering iron, connect the wires, **OF THE SAME COLOR**, of the male and female wires
11. Slide the heat retracting cover over the connection



Do not heat up the wires too much while you are connecting them, there is the risk that the material shrinks in the wrong position

12. Repeat the point from 7 to 9
13. Take the heat gun and heat up the heat retracting cover, be sure that they are in position before heating them up



DO NOT TOUCH the metal parts of the heat gun.



When managing it, be sure to NOT point it in the direction of anyone or anything heat affectable.

14. Connect the just created wire extension to one of the batteries
15. Take the motor enclosure part A and set it on the clamp with the three holes part put horizontally
16. Take three 4-40 inserts and, using the soldering iron, insert them, one at a time, in the holes



The two holes that will be used to tight the motor enclosure on the rod are through holes, so you can insert the top of the pipe in the hole of the insert and push the insert in. For the other hole this is not possible as the hole is blind, apply light pressure on the insert with the tip of the soldering iron until it is completely inside the hole



Be sure not to touch the plastic with the pipe, at these temperatures it melts the plastic instantly



If one of the inserts slips away from the hole while you are heating it up, **DO NOT TOUCH IT** with your hands as it is very hot. Use pliers or the pipe itself to pick it up. If it falls on your clothes rapidly remove it as it can burn and leave some marks on them

17. Turn the motor enclosure into the clamp and insert the last 4-40 insert.
18. Remove the motor enclosure from the clamp. After points 17 and 18 you must be in this situation:



19. Take the battery without the extension and insert it into its hole with the wire that exits from below. See pictures below for more details:





Use a small allen key to direct the wire in the hole in the bottom of the motor enclosure. You can use it also to push the battery in the hole

20. Insert the other battery on top of the previous one, with the wires outgoing from above

21. Insert the wires from the upper battery in the channel and the white connecting part in the enlargement of the channel, the result must be the one shown in the pictures below:



22. Insert the motor in its hole with the wire exiting from below. Push it in until you hear a slight “click”, just like in the picture below:



23. Take one of the 4-40 screw and insert in the side hole, in this way the motor will be blocked in position

24. Take the motor enclosure part B, insert the non-wrapped fishing line in the small hole on the side of it, see the picture below for details:

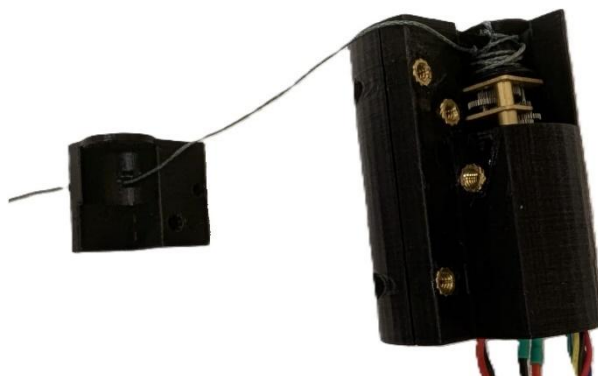

25. Fix the position of the motor enclosure part B with a 4-40 screw

26. Insert the sensor's connectors in the small channel

27. Add some tape in a way that the cables are fixed in position, as in the pictures below:

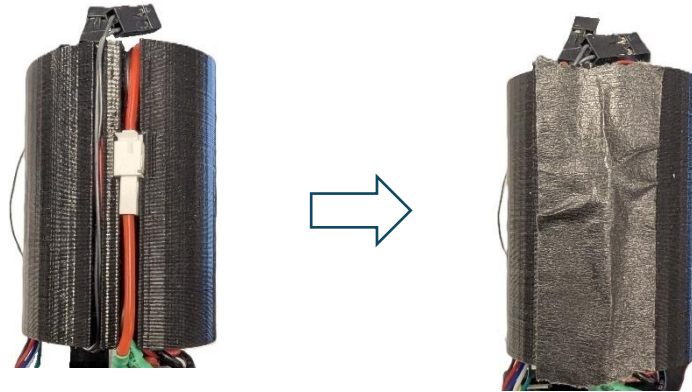

Electronics enclosure – Part A



Things you'll need – per part

- [2-56 Heat-Set Threaded Inserts](#): 4
- [4-40 Heat-Set Threaded Inserts](#): 2
- **Soldering iron**: 1
- **Time**: ~ 5 minutes

Further assembly

1. Using the Soldering iron, push the 2-56 inserts in position. These are blind holes so you must push them slowly
2. Turn the piece and insert the 4-40 inserts in the holes previously freed. These are through holes so you can insert the tip of the pipe in the insert to push them. When they arrive in position, you can remove the pipe

End caps

Each rod has 2 of these



When touching anything related to this part **WEAR GLOVES**, the uncured resin is toxic



Things you'll need – per cap

- **Formlabs printer:** 1
- **Material for the 3D printer: Resin Tough 2000:** as much as needed
- **Plies:** 1
- **Flat screwdriver:** 1
- **Toothpicks:** as much as needed
- **Paper towels:** as much as needed
- **Tweezers:** 1
- **Curing station:** 1
- **Container:** ideally 2
- **Isopropanol:** as much as needed
- **Hazardous materials bucket: tough2000 or equivalent:** 1
- **Gloves:** as much as needed
- **Laboratory coat:** 1
- **Protective goggles:** 1
- **Compressed air:** as much as needed
- **Fume hood:** 1
- **Time:** ~ 7 hours: 4 for the print, 3 for the post-print curing

Prior preparations

1. These parts can be printed in batches
2. During the uploading of the project, you must select:
 1. Orientation: with supports on the hemispherical part
 2. Supports: needed

After the print curing process

1. **Wear gloves, protective goggles and lab. Coat**
2. Take a lot of paper towels, in proportion to the number of parts you printed, **consider at least two towels per part plus five towels to clean everything else**, and bring them under the fume hood or in a well-ventilated area

3. Take the screwdriver, the tweezers, and the toothpicks, **take at least one toothpick per part you printed**, and bring them under the Fume hood
4. Take off the entire platform on which the parts are attached, **lift the small part on top and simply pull the platform**



Wrap the whole platform in a paper towel, in this way you will have cleaner gloves and you will work better

5. Bring the platform under the Fume hood



Remember to pull the curtain as low as possible to keep the air flow in the Fume hood constant, but high enough to permit you to work fine

6. Remove the parts from the platform, remove every support left on the part with the tweezers and the screwdriver, **typically under the hooks**, clean the hole with a toothpick and clean the surface of the part with a paper towel and a lot of Isopropanol
7. Clean the platform from the remaining supports with the screwdriver, the tweezers and plenty of Isopropanol



Try to lift the base of the support and to insert the screwdriver or the tweezers under it, if you try to pull it directly from the support it will not work, add plenty of Isopropanol to help detach them

8. Clean the platform from every trace of resin with abundant Isopropanol and paper towels, not only the metal part of the platform but also the other sides
9. Clean the tools you used, the screwdriver and the tweezers, from every trace of resin with abundant Isopropanol
10. **Throw all the used paper towels, the removed supports, the used toothpicks, and every remaining part of resin in a separate bucket, NOT IN THE GENERAL ONE. Remember that the Tough 2000 is toxic**
11. Wrap the cleaned parts in a paper towel and do the same thing with the platform, in this way you will prevent any major contamination of these parts with the resin present on your gloves
12. Put the platform back in the printer
13. Put the parts in the first stage container with the Isopropanol, to clean the big part of the remaining resin, **wear gloves**
14. Wait 60 minutes
15. **Wear gloves, protective goggles and lab. Coat**
16. Take some paper towels, **at least one per printed part plus two**, toothpicks, at least one per printed part, tweezers and the Isopropanol
17. Take off the parts from the bath and wrap them in a paper towel
18. Bring them near a source of compressed air
19. Clean them again with the Isopropanol, remove all the residual parts of resin remaining on the part, clean the hole with the toothpick and blow dry the whole part, **especially the hole**, with the compressed air
20. Put them in the curing station for 1 hour, this will fix the resin

Electronics

Motherboard

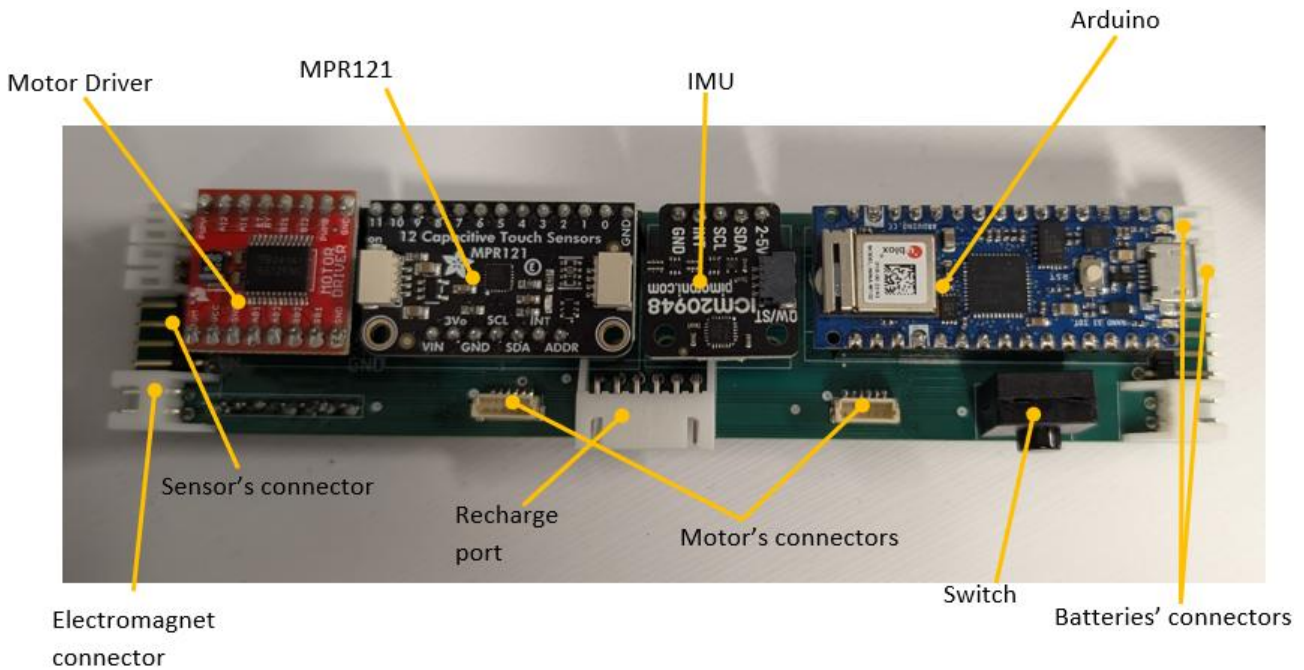

Things you'll need – per motherboard

- **Motherboard:** 1
- **Batteries connector ([JST-XH 2pos connector](#)):** 4
- **Sensors connector ([4x1 right angle male header pins](#)):** 2
- **Charging port ([JST-XH 6pos connector](#)):** 1
- **Motors connector ([JST-SH 6pos connector](#)):** 2
- **[1kΩ resistor](#):** 3
- **[MOSFET N/P-CH](#):** 3
- **[15x1 female headers](#):** 1
- **[13x1 female headers](#):** 1
- **[8x1 female headers](#):** 2
- **[7x1 female headers](#):** 1
- **[5x1 female headers](#):** 1
- **Electromagnet connector ([JST-PH 2pos connector](#)):** 2
- **Tweezers:** 1
- **Syringe with needle:** 1
- **Toothpicks:** as much as needed
- **Mask for paste:** 1
- **[SPST Pushbutton Switch](#):** 1
- **Assembled power sensor:** 1
- **Assembled IMU:** 1
- **Assembled motor driver:** 1
- **Assembled MPR121:** 1
- **Assembled Arduino:** 1
- **Solder:** as much as needed
- **Soldering iron:** 1
- **Breadboard:** 1
- **Paper towels:** as much as needed
- **Soldering paste (aka reflow solder):** as much as needed
- **Oven:** 1
- **Time:** 20 minutes

Prior preparations

1. Heat up the oven to a temperature of 250 °C
2. Prepare some paper towels, **at least three** and some toothpicks, **at least two**

Preparation

1. Using the mask, apply the solder paste for the pads on the motherboard, the pads are shown in the pictures below:

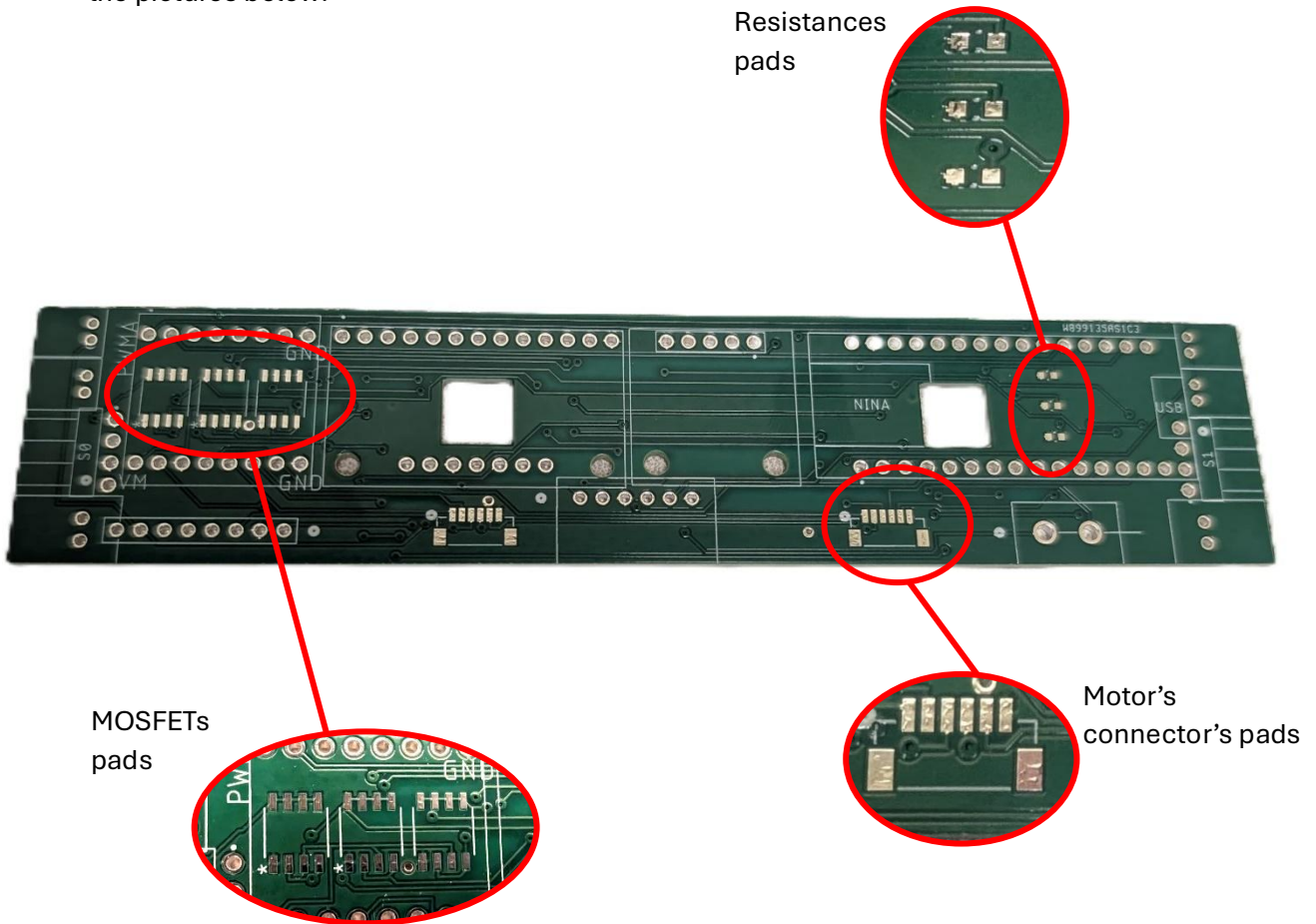

2. Using the pictures above, position carefully the different componts on their pads:
 - I. **Motors connector (JST-SH 6pos connector)**: position them as shown in the pictures below, please see the right positioning in the first picture, any other positioning is wrong:

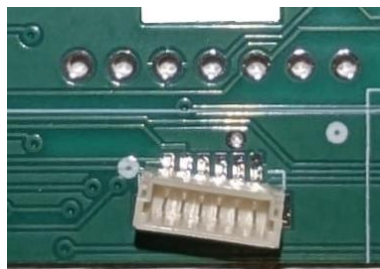

Use the tweezers for better positioning



Try not to drag them onto the surface of the motherboard, if the paste spreads you must restart from point 1

II. **MOSFETs (MOSFET N/P-CH)**: see the MOSFET in the picture below, note the dot in the left bottom angle:

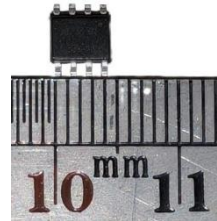

position the MOSFETs on their pads as shown in the pictures below, please see the right positioning in the first picture, any other positioning is wrong. **Be extremely careful, they are very small and even using the tweezers they can fall or slip on the motherboard ruining the paste's marks (see picture above to understand the dimensions).**



You must position the dot on the MOSFET near the "*" on the motherboard.

III. **1kΩ resistors**, they must be positioned with the black part on top. **Be extremely careful, they are extremely small and even using the tweezers they can fall or slip on the motherboard ruining the paste's marks, they are very difficult to position in the right way so help yourself with the tweezers and the toothpicks.** See the pictures below for details on the resistors.

Note: for the resistor positioning them on the motherboard would not be very clear so a white background was chosen.

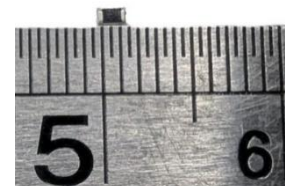

3. Insert the motherboard in the preheated oven for **5 minutes**
4. **Using the tweezers**, remove the motherboard from the oven, put it on a table and let it cool down

You must be in this configuration:

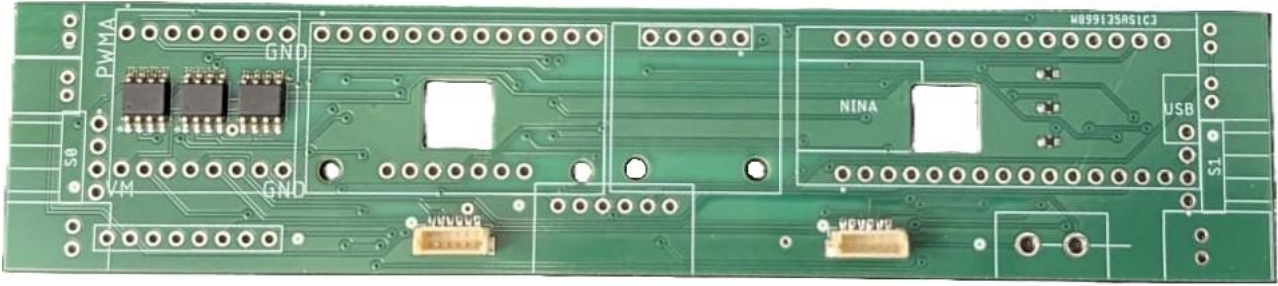

 You can use the 3D printed mask for assembling the motherboard*

5. If you are using the 3D printed mask for the assembly, you can position every piece in the following list in the fixture and place the components in their positions as shown in the pictures below. You must pay attention that the motherboard is always parallel to the fixture and that there are no components in the wrong position. If you are doing so, please jump to step 7
 - I. Red: female headers
 - II. Green: batteries connectors ([JST-XH 2pos connector](#))
 - III. Blue: sensors connectors ([4x1 right angle male header pins](#))
 - IV. Yellow: electromagnet connectors ([JST-PH 2pos connector](#))
 - V. Brown: charging port ([JST-XH 6pos connector](#))
 - VI. Purple: switch ([SPST Pushbutton Switch](#))
 - VII. Light blue: power sensor



To avoid errors, check the sides of the fixture and you will see which side is which, as shown in the pictures below:

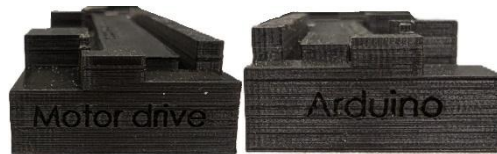

6. If you do not want to use the mask as in point 7, please see the following points:
 - I. Solder one of the sensors connector ([4x1 right angle male header pins](#)) to the motherboard, **help yourself with the breadboard if you need**, and be sure that the black part is in contact with the motherboard and that the pins are parallel to the long side of the motherboard
 - II. Repeat step I for the other sensors connector
 - III. Solder the batteries connector ([JST-XH 2pos connector](#)) to the motherboard, all four. **Be sure that their lower part is in contact with the motherboard**. It can be a problem later if they are not soldered in the right position. Be sure that they are inside the white rectangle and that they are in contact with the surface of the motherboard
 - IV. Solder the electromagnet connector ([JST-PH 2pos connector](#)) to the motherboard. As before, be sure that their lower part is in contact with the motherboard
 - V. Solder the recharge port ([JST-XH 6pos connector](#)) to the motherboard and be sure that its lower part is in contact with the motherboard
 - VI. One at a time, solder the head connectors. **DO NOT INSERT** a head connector in the 8x1 spot near the motor's connectors

⚠ For the head connectors, you must be very careful, they must be parallel as much as possible to one another and to the sides of the motherboard. They also must be perpendicular to motherboard itself

VII. Rotate the motherboard

VIII. In the 8x1 free spot, position the power sensor, without a head connector. Be sure that it is parallel to the motherboard and that the black part of the connector is in contact with the motherboard

See the picture below to better understand the process:

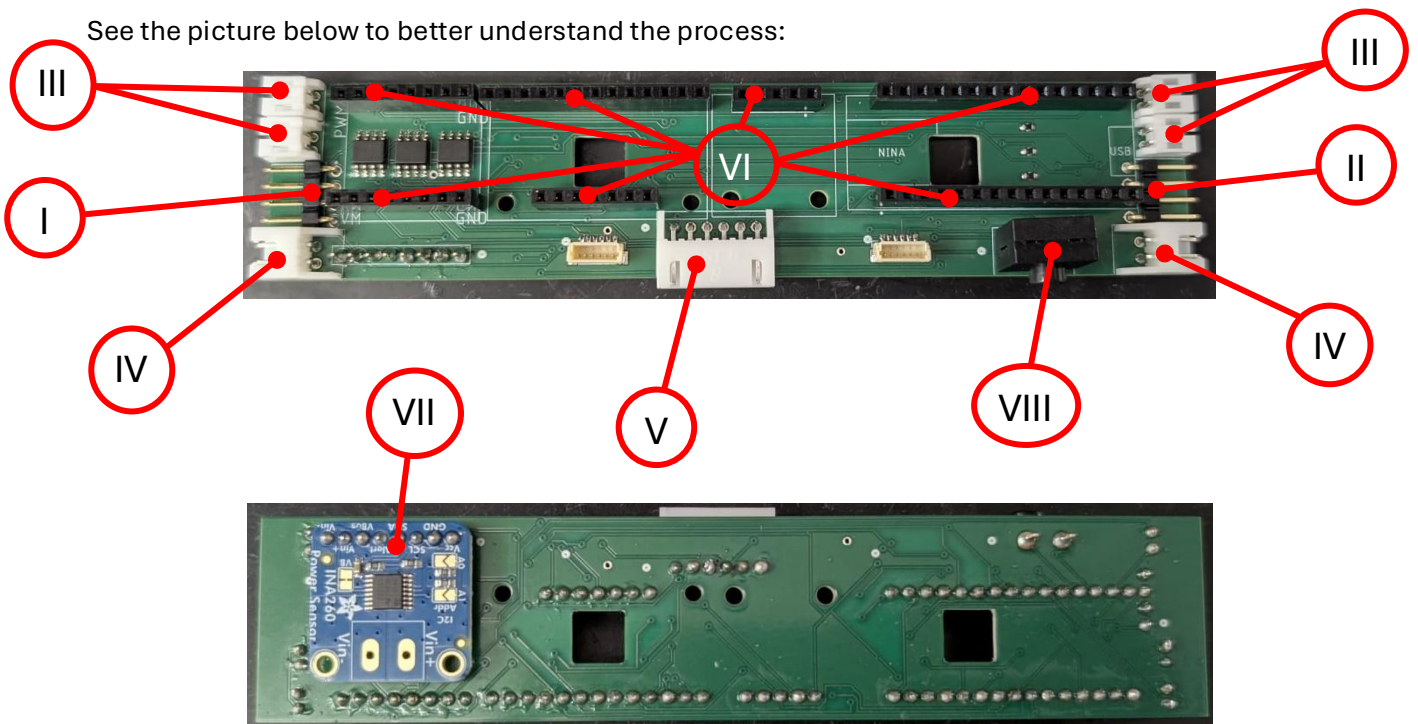

If, for some reason, you do not want to add the power sensor, you must seal the two most external holes in the motherboard in the 8x1 power sensor spot, as shown in the picture below:

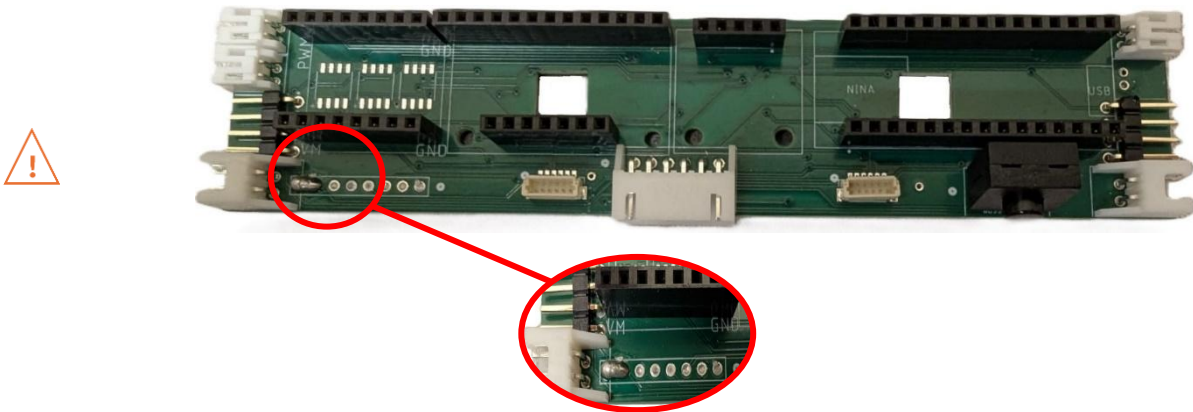





IX. Add the switch, which must be parallel to the sides of the motherboard and solder the extremities in the back

7. Add the preassembled boards. After point 7 you must be in this situation:

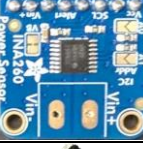

Other components

Parts		Header pins	Time needed	Further cures
Name	Picture			
Arduino Nano 33 IoT		15x1: 2	10 min	None
Capacitive Sensing Breakout MPR121		13x1: 1 7x1: 1	10 min	None
Dual TB6612FNG Motor Driver		8x1: 2	10 min	None
Adafruit INA260 Power Meter		8x1: 1	20 min	Remove the black part
Pimoroni ICM20948 9-axis IMU		5x1: 1	5 min	None

Final assembly of the rod

After assembling all the different parts, it is now time to assemble the bar

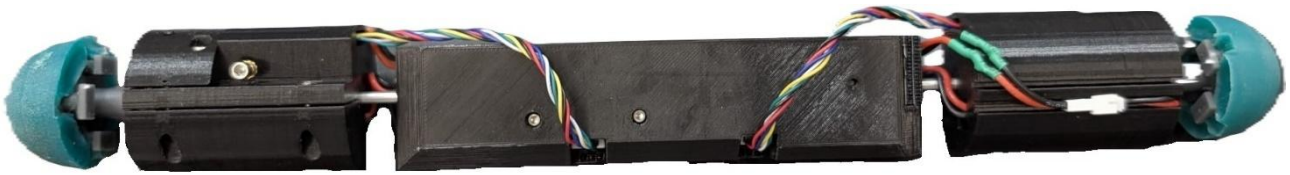

Things you'll need – per rod

- [1/8" Aluminum Rod, 12" Long](#): 1
- [Endcap](#): 2
- [Endcap cover](#): 2
- [Assembled motor enclosure](#): 2
- [Electronic enclosure – part A](#): 1
- [Electronic enclosure – part B](#): 1
- [Assembled motherboard](#): 1
- [Assembled IMU](#): 1
- [Spacer](#): 2
- [2-56 Socket Head Cap Screws](#): 4
- [4-40 Socket Head Cap Screws](#): 6
- [Allen keys](#): 2
- [Jumpers](#): 4
- [Time](#): 20 minutes

Preparation

1. Put the motherboard in the electronic enclosure - part A
2. Take the IMU, two 2-56 screw and two spacers: insert the screw in the holes in the IMU and, on the other side, the spacers
3. Put the IMU in position on the motherboard and fix the screws on the electronic enclosure, just like in the picture below:

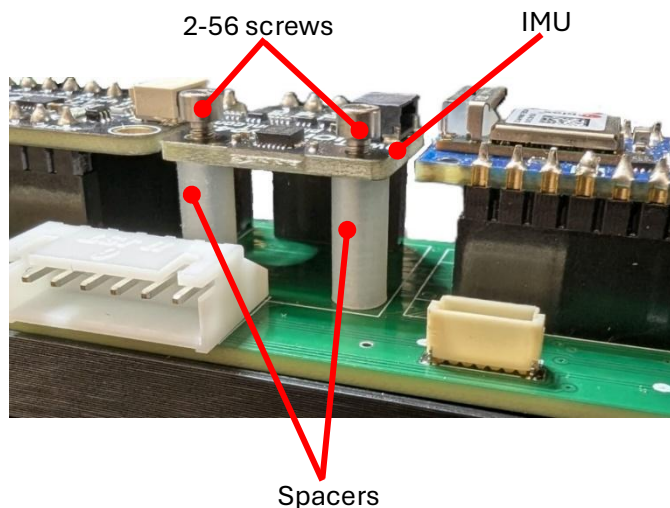

4. Take the metal rod and insert it in the holes in the electronic enclosure
5. Take one of the two motor enclosure e insert it on the metal rod, leaving ~30 mm of space after the enclosure. It must be like the picture below:

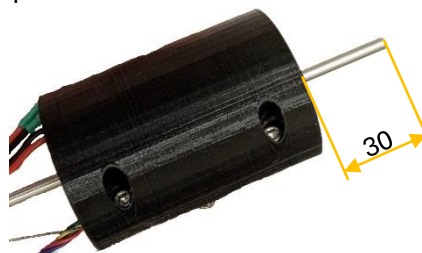

6. Connect the batteries to the motherboard at the batteries connectors ([JST-PH 2pos connector](#))
7. Insert the jumpers into the sensors connector ([4x1 right angle male header pins](#)), and in the small channel in the end mount



In the two sides, and in the other rods, always use the same position for the two wires: put the red wire near the batteries' connectors, and the black wire near the sensors connector

8. Take two 4-40 screws and fix the position of the motor enclosure thanks to the clamp on the rod
9. Repeat steps from 5 to 8
10. Take two 4-40 screws and fix the position of the electronic enclosure and of the motherboard on the rod, **be careful** not to tight the screws too much or the electronic enclosure could break
11. Take the electronic enclosure part B and cover the motherboard, use two 2-56 screws to fix the position of the enclosure
12. Take the two endcaps ends put them on the extremities of the metallic rods
13. Put the endcap covers on the endcaps

Final assembly of the robot – 3 bars

Things you'll need – for a 3-bars robot

- **Assembled bar:** 3
- **Long sensor:** 3
- **Short sensor:** 6
- **Tweezers:** 1
- **Time:** 30 minutes

Prior preparation

1. Make sure that the fishing line coming from the motor is at least 150 mm long
2. Position all the bars with the Arduino port on the same side

Preparation

For the fishing lines:



It does not matter which of the hooks on the end caps the fishing line is connected to

1. Looking at the bar from the side of the Arduino ports connect:
 1. **BLUE** motor to **GREEN** end cap
 2. **GREEN** motor to **RED** end cap
 3. **RED** motor to **BLUE** end cap
2. Looking at the robot from the other side connect:
 1. **BLUE** motor to **GREEN** end cap
 2. **GREEN** motor to **RED** end cap
 3. **RED** motor to **BLUE** end cap

In the pictures below how to connect the cables, the orange arrows show the directions on the two sides:

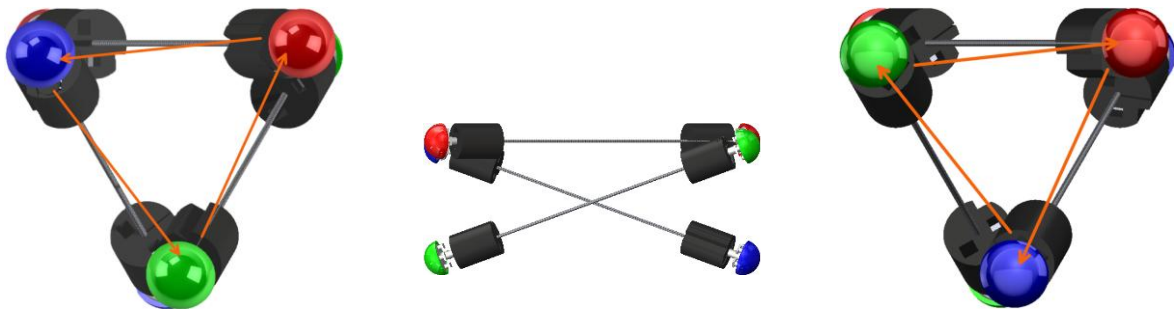

For the long sensors:

 The long sensors must be connected not in parallel to the fishing lines

 The long sensors must be connected to the opposite hook of the fishing line

 It is better to connect the sensor first to the side at the side of the Arduino

1. **RED** to **BLUE**
2. **BLUE** to **GREEN**
3. **GREEN** to **RED**

In the picture below how to connect the long sensors:

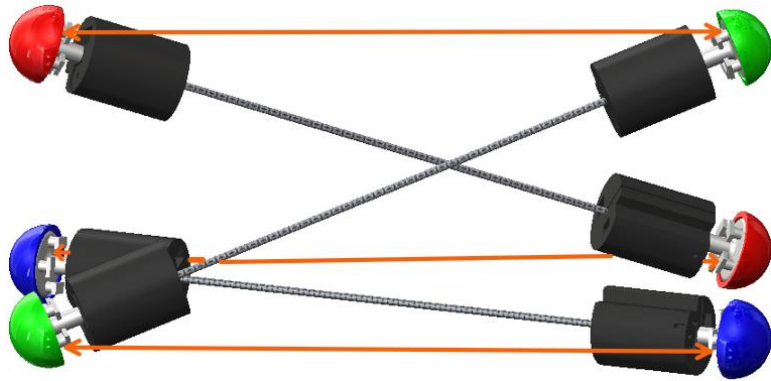

The short sensors must be connected in parallel to the fishing lines. The connection wires must be in the same side of the motor. See the images below to better understand, note that the arrows are directed from the motor side to the end cap:

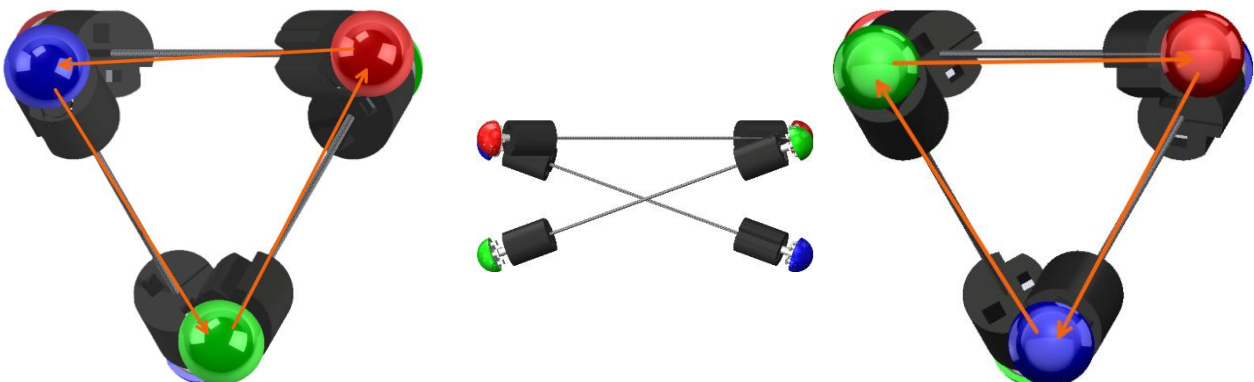

NOTE: in the 3-bars configuration there will be some wires for the sensors unused, it is fine, they will be used for other configurations. Just tape them near the other wires.

For what concerns the connection of the sensors to the motherboard, the long sensor must be connected near the battery connectors and the short sensor near the electromagnet connector. So there will be:

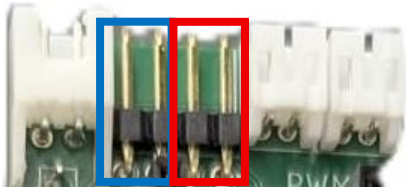

Red: Long sensor

Blue: Short sensor

The sensors must be connected in the same position on both sides, so you will have the long sensor connected near the battery connectors on both sides.

Since there are only three long sensors, there will be only one sensor plugged in on each motherboard, on the other side only the jumper is connected.

THE FINAL RESULT IS THIS!

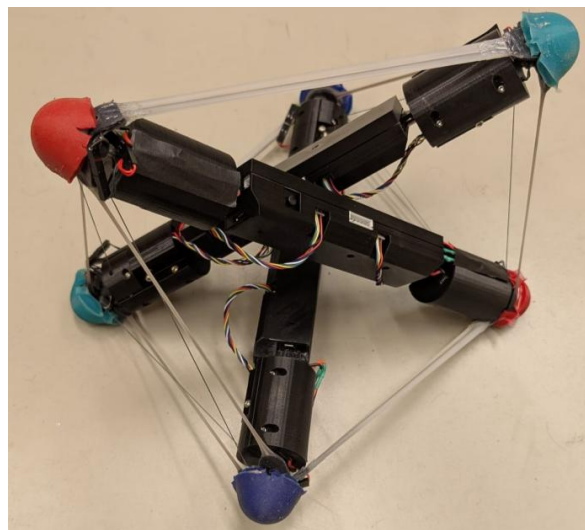

EXTRAS

Connector for recharge station



Things you'll need – per connector

- **Red wire Φ 2mm:** 2x150 mm
- **Black wire Φ 2mm:** 2x150 mm
- **White wire Φ 2mm:** 2x150 mm (In the photo above there are no white wires because it was an old design)
- **JST-XH crimps:** 12
- **6x1 JST-XH crimps housing:** 1
- **3x1 JST-XH crimps housing:** 2
- **Wire cutter:** 1
- **Wire stripper:** 1
- **Crimper:** 1
- **Soldering iron:** 1
- **Solder:** as much as needed
- **Ruler:** 1
- **Tweezers:** 1
- **Clamp:** 1
- **Time:** 20 minutes

Preparation

1. Cut the wires as indicated above
2. Strip both the ends of the wires, about 3 mm
3. Insert the wire in the crimp and **bend the two small fins to secure the position of the crimp on the wire**
4. Seal the crimp with the crimper
5. Add a drop of Solder on the exposed wire inside the crimp to fix the position. If you add too much Solder, you will end up closing the channel and you must cut away the crimp and restart from point 2
6. Insert the wire in the 3x1 connector as shown in the figure below

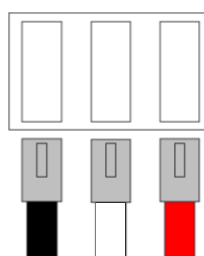

7. Put the connector in the clamp
8. Create a loose braid with the wires, you must end up with the wire in the same reciprocal position one to another
9. Take the 6x1 connector and insert wires as in the figure below. You are making the three wires framed in green

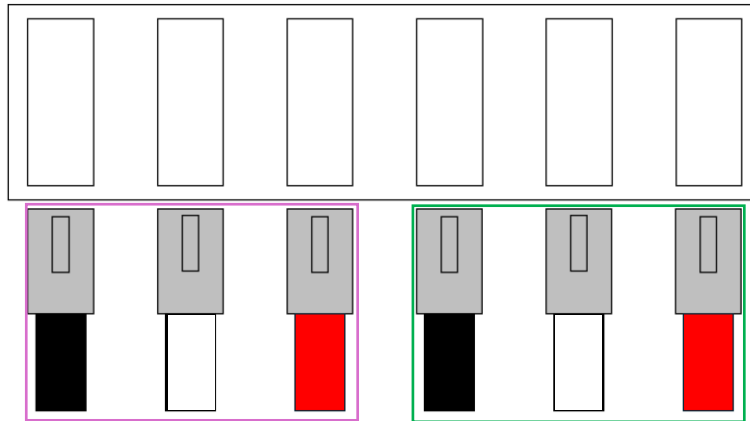

10. Repeat the points from 1 to 10 and insert the wires as in the figure above, the three wires framed in purple

How to charge the robot

Things you'll need

- **Battery Charger:** 2
- **Connector for recharge:** 6
- **3-bars robot:** 1
- **12 V power cord:** 2

Procedure

1. Connect the connector to the battery charger, like in the picture below:



2. Connect the connector the one of the rods
3. Repeat points 2 and 3 for each rod
4. Connect the battery chargers to the 12 V power cords

5. Press the button to the left, the start/stop button, as in figure below:

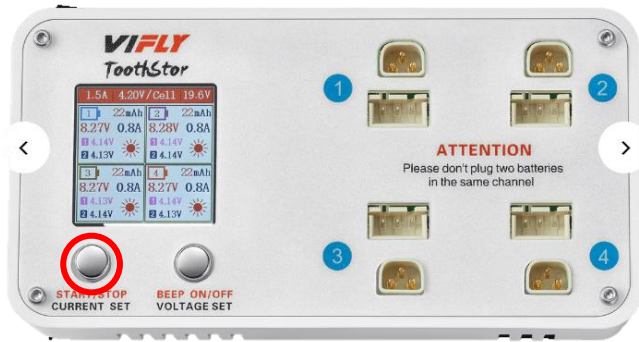

How to switch on/off the rods

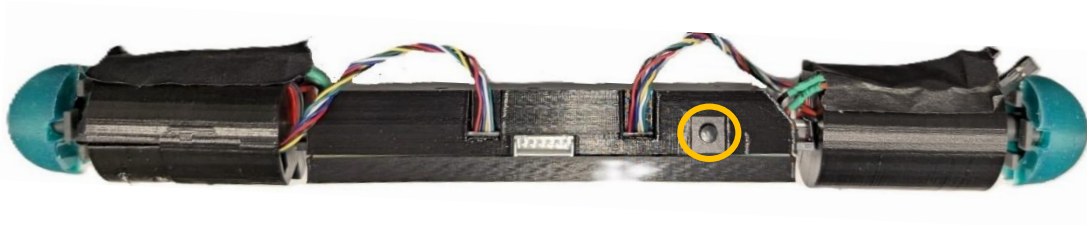

To switch on and off the rod press the button switch in the side if the rod, near the charging port. The rods must be turned off when you finish working with the robot in order to not discharge the batteries. It's also useful to turn off and on again the rod in case there are some problems with it, for example if the rod does not connect to the PC.

How to upload the code in the rod



To upload the code on the rod, connect the [Micro USB Right Angle Adapter](#) to the rod through the door, circled in yellow in the picture, and to the pc.